

H Series PLC HITACHI

MICRO-EH 64pts Expansion unit

Instruction manual

Thank you for purchasing a Hitachi Programmable Logic Controller. To operate it safely, please read this instruction manual and all the user manuals carefully. Please be sure to use the latest versions of user manuals and keep them at hand of end users for future reference.

Caution

1. All rights reserved.
2. The content of this manual may be changed without notice.
3. While efforts have been made on this manual to be accurate, please contact us if any mistakes or unclear part is found.

■ Warranty period and coverage

The warranty period is either 18 months after manufacturing date (MFG No) or 12 months after installation. Examination and repair within the warranty period is covered.

However within the warranty period, the warranty will be void if the fault is due to;

- (1) Incorrect use from instructed in this manual and the application manual.
- (2) Malfunction or failure of external other devices than this unit.
- (3) Attempted repair by unauthorized personnel.
- (4) Natural disasters.

The warranty is for the PLC only, any damage caused to third party equipment by malfunction of the PLC is not covered by the warranty.

■ Repair

Any examination or repair after the warranty period is not covered. And within the warranty period any repair and examination which results in information showing the fault was caused by any of the items mentioned above, the repair and examination cost are not covered. If you have any questions regarding the warranty or repair cost, please contact your supplier or the local Hitachi Distributor. (Depending on failure part, repair might be impossible.)

■ Ordering spare parts and inquiries

Please contact your local suppliers for ordering products/spare parts or any inquiries with providing the following information.

- (1) Product name
- (2) Manufacturing number (MFG No.)
- (3) Details of failure

Safety precautions

■ Definitions and Symbols



DANGER

Indicates a potentially hazardous situation which, if not avoided, can result in serious injury or death.



CAUTION

Indicates a potentially hazardous situation which, if not avoided, can result in minor to moderate injury, or serious damage of product.





: Indicates prohibition



: Indicates Compulsion

	DANGER
<ul style="list-style-type: none"> - Do not touch terminals while power ON. There is a danger of electric shock and/or injury. - Be sure to install external safety devices outside of the PLC like emergency stop circuit or interlock circuit. 	

	CAUTION
<ul style="list-style-type: none"> - Be sure that the rated voltage matches the power supply voltage of the unit. Otherwise, there is a danger of breakdown and/or injury and/or fire. - Only qualified personnel shall carry out wiring work. Otherwise, there is a danger of breakdown and/or injury and/or fire. 	

	COMPULSION
<ul style="list-style-type: none"> - Be sure to ground the unit. Otherwise, there is a danger of electric shock and/or malfunction. 	

	PROHIBITION
<ul style="list-style-type: none"> - Do not attempt to modify nor disassemble the unit. There is a danger of breakdown and/or injury and/or fire. 	

■ Mounting

- Mount the PLC on a metal plate and install in a cabinet as follows.
- Be sure to ground the cabinet and the metal plate, otherwise there is a risk of malfunction.
- Install the PLC as described in user manual.
- Take appropriate measures when the PLC system installed in locations :
 - Influenced easily due to noise or static electricity or other forms of noise.
 - Under strong electromagnetic field.
 - Close to power supplies.
- Be sure to tighten mounting screws, terminal screws and connector screws.
- Be sure to check that devices with lock mechanism, such as an expansion cable or terminal blocks, are locked properly.

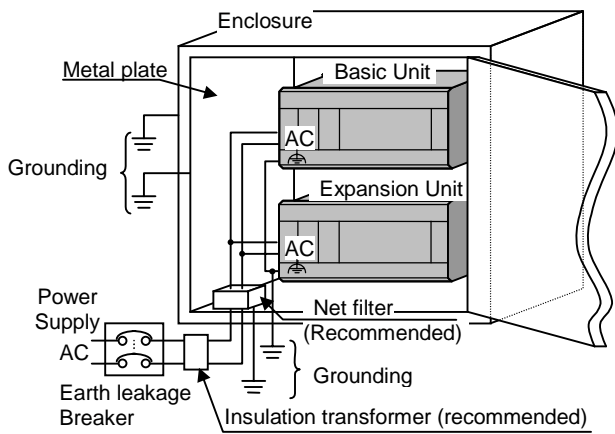

Figure 1 Power wiring example

Table 1 Specifications of the net filter

Item	Spec.
Rated voltage	250 VAC
Rated current	5 A
Withstand voltage (V) (between Terminal and case)	1500 V
Insulation resistance (MΩ) (500VDC, 1 min., between terminal and case)	min. 100 MΩ
Attenuation	Differential mode, more than 40dB
Frequency range (MHz)	0.5 - 30
	Common mode, more than 40dB
	0.15 - 30

Reference : EMC filter ZAC2205-00U (TDK)

■ Power Wiring

- Appropriate emergency circuitry, interlock circuitry and similar safety measures should be added to the system.
- Appropriate safety measures should be included in the system for unexpected breaking of wire or malsignal caused from instantaneous power failure.
- Applied voltage must be in the range specified in the manual. Otherwise, there is a danger of breakdown and/or injury and/or fire.
- Install an external earth leakage breakers to avoid short circuit accident.
- In case of the following operations, turn off power. Otherwise, there is a danger of breakdown and/or injury and/or fire.
 - Mounting or dismounting CPU and I/O modules.
 - Assembling cabinet or machine including PLC.
 - Wiring.
- Install net filter specified in table-1 or similar. The input and output cable of the net filter should be separated as much as possible. Be sure to ground the net filter.
- A shielded and insulated transformer is recommended.
- The basic and expansion unit should be connected to common power source and powered up together as shown in fig.1.
- Install a lightning arrester
To prevent damage to the equipment as a result of being struck by lightning, it is recommended that a lightning arrester be installed for each PLC's power supply circuit.

■ I/O Wiring

- Be sure that the input/output voltage matches the specified voltage. Otherwise, there is a danger of breakdown and/or fire.
- Use shielded cable for relay outputs module, and connect shields to a functional ground for one side or both sides depending on applications.
- Route the AC power line and I/O lines separated as much as possible. Do not route both cables in a same duct.
- Route the I/O lines and data lines as close as possible to the grounded surfaces such as cabinet elements, metal bars and cabinets panels.

■ Common precautions

- Use proper cable ferrules for terminals. Using improper cable ferrules or connecting bare wires to terminals directly might result in fire.
- Do not turn on power, if the unit appears damaged.
- Be sure to check all the field wiring before PLC power on. Otherwise, there is a risk of fire.
- Do not attempt to disassemble, repair or modify any part of the PLC.
- Do not pull on cables or bend cables beyond their natural limit. Otherwise, there is a risk of breaking of wire.
- Keep PLC modules in their boxes during storage and transport.
- Check carefully your PLC program before operation.

Installation environment

Avoid the following locations to install the PLC.

- Excessive dusts, salty air, or conductive materials (iron powder, etc.)
- Direct sunlight.
- Temperature less than 0°C or more than 55°C.
- Humidity less than 5% or more than 90%.
- Dew condensation.
- Direct vibration or impact to the unit.
- Corrosive, explosive or combustible gases.
- Water, chemicals or oil splashing on the PLC.
- Close to noise emission devices.

Reference Manual

Read the following application manual carefully to use the PLC safely and properly. Be sure to keep the latest version.

Manual name	Manual No.
MICRO-EH APPLICATION MANUAL	NJI-350* (X)
MICRO-EH BASIC UNIT (20/40/64 points type) APPLICATION MANUAL	NJI-465* (X)

* : The alphabet between 350 and (X) means version (A,B,...).

Input specification

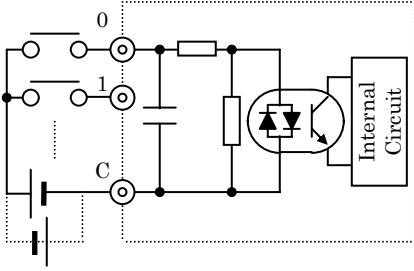
Item	Specification		Internal Circuit	
	X0, X2, X4, X6	Except the following		
Input voltage	24V DC			
Allowable input voltage range	0 to 30V DC			
Input impedance	Approximately 2.7 kΩ	Approximately 4.7 kΩ		
Input current	8 mA typical	4.8 mA typical		
Operating voltage	ON voltage	18 VDC (min) / 4.5mA (max)		18 VDC (min) / 3.3mA (max)
	OFF voltage	5 VDC (min) / 1.8mA (max)		5 VDC (max) / 1.6mA (max)
Input lag	OFF → ON	2 ms or less		
	ON → OFF	2 ms or less		
Number of input points	40 pts. (Refer to Terminal layout and wiring)			
Number of common points	2 pts. (Refer to Terminal layout and wiring)			
Polarity	None			
Insulation system	Photocopler insulation			
External connection	Removable type screw terminal block (M3)			

Output specification

(1) Relay output (All outputs of EH-A64EDR and EH-D64EDR)

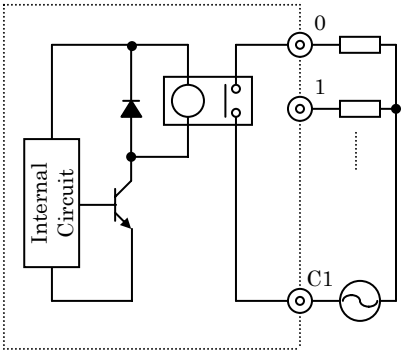
Item	Specification		Internal Circuit
	1 circuit	1 common	
Rated load voltage	5 to 250V AC, 5 to 30V DC		
Maximum load current	2A (24V DC, 240V AC)		
Output response time	OFF → ON	15 ms (max)	
	ON → OFF	15 ms (max)	
Number of output points	24 pts. (Refer to Terminal layout and wiring)		
Number of common points	9 pts. (Refer to Terminal layout and wiring)		
Surge removal circuit	None		
Fuse	None		
Insulation system	Relay insulation		
External connection	Removable type screw terminal block (M3)		
Contact life	20,000,000 times (mechanical)		
	200,000 times (electrical : 1.5A)		
Insulation	1500V or more (external - internal) 500V or more (external - external)		

(2) Transistor output (Y100-Y103 of EH-D64EDT)

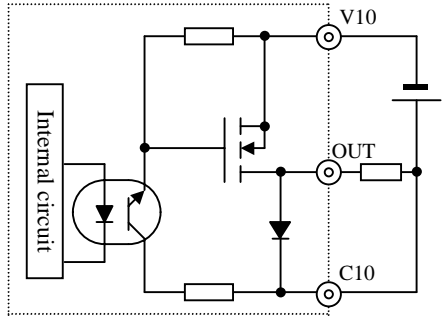
Item	Specification	Circuit diagram	
Output specification	Transistor output	Sink type [EH-D64EDT] (Y100-Y103) 	
Rated load voltage	24/12 V DC (+10 %, -15 %)		
Minimum switching current	10 mA		
Leak current	0.1 mA (max)		
Maximum load current	1 circuit		0.5 A 24 V DC / 0.3 A 12 V DC
	1 common		2 A
Output response time	OFF → ON		5 μs (max) 24 V DC 0.2A
	ON → OFF		5 μs (max) 24 V DC 0.2A
Number of output points	4 pts. (Refer to Terminal layout and wiring)		
Number of common *1	1 pts. (Refer to Terminal layout and wiring)		
Surge removing circuit	None		
Fuse	None		
Insulation system	Photocoppler insulation		
External connection	Removable type screw terminal block (M3)		
Externally supplied power *1	12 to 30 V DC		
Insulation	1500 V or more (external-internal)		
	500 V or more (external-external)		
Output voltage drop	0.3 V DC (max)		

*1: It is necessary to supply 12 to 30 V DC between the V and C terminals externally.

(3) Transistor output (Y104-Y123 of EH-D64EDT)

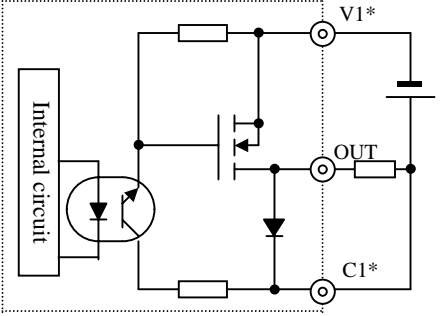
Item	Specification	Circuit diagram	
Output specification	Transistor output	Sink type type [EH-D64EDT] (Y104-Y123) 	
Rated load voltage	24/12 V DC (+10 %, -15 %)		
Minimum switching current	10 mA		
Maximum load current	1 circuit		0.5 A
	1 common		3 A
Output response time	OFF → ON		0.1ms (max) 24 V DC
	ON → OFF		0.1ms (max) 24 V DC
Number of output points	20 pts. (Refer to Terminal layout and wiring)		
Number of common	3 pts. (Refer to Terminal layout and wiring)		
Surge removing circuit	None		
Fuse	None		
Insulation system	Photocoppler insulation		
External connection	Removable type screw terminal block (M3)		
Externally supplied power *1	12 to 30 V DC		
Insulation	1500 V or more (external-internal)		
	500 V or more (external-external)		
Output voltage drop	0.3 V DC (max)		

*1: It is necessary to supply 12 to 30 V DC between the V and C terminals externally.

(4) Transistor output (Y100-Y103 of EH-D64EDTPS)

Item		Specification	Circuit diagram
Output specification		Transistor output	<p>Source type [EH-D64EDTPS] (Y100-Y103)</p>
Rated load voltage		24/12 V DC (+10 %, -15 %)	
Minimum switching current		10 mA	
Leak current		0.1 mA (max)	
Maximum load current	1 circuit	0.5 A 24 V DC / 0.3 A 12 V DC	
	1 common	2 A	
Output response time	OFF → ON	5 μs (max) 24 V DC 0.2A	
	ON → OFF	5 μs (max) 24 V DC 0.2A	
Number of output points		4 pts. (Refer to Terminal layout and wiring)	
Number of common		1 pts. (Refer to Terminal layout and wiring)	
Surge removing circuit		None	
Fuse		None	
Insulation system		Photocoppler insulation	
External connection		Removable type screw terminal block (M3)	
Externally supplied power *1		12 to 30 V DC	
Insulation		1500 V or more (external-internal) 500 V or more (external-external)	
Output voltage drop		0.3 V DC (max)	

*1: It is necessary to supply 12 to 30 V DC between the V and C terminals externally.

(5) Transistor output (ESCP type) (Y104-Y119 of EH-D64EDTPS)

Item		Specification	Circuit diagram
Output specification		Transistor output (with short-circuit protection)	<p>Source type [EH-D64EDTPS] (Y104-Y119)</p>
Rated load voltage		24/12 V DC (+10 %, -15 %)	
Minimum switching current		10 mA	
Leak current		0.1 mA (max)	
Maximum load current	1 circuit	0.7 A	
	1 common	3 A	
Output response time	OFF → ON	0.5 ms (max) 24 V DC	
	ON → OFF	0.5 ms (max) 24 V DC	
Number of output points		16 pts. (Refer to Terminal layout and wiring)	
Number of common		2 pts. (Refer to Terminal layout and wiring)	
Surge removing circuit		None	
Fuse		None	
Insulation system		Photocoppler insulation	
External connection		Removable type screw terminal block (M3)	
Externally supplied power *1		12 to 30 V DC	
Insulation		1500 V or more (external-internal) 500 V or more (external-external)	
Output voltage drop		0.3 V DC (max)	

*1: It is necessary to supply 12 to 30 V DC between the V and C terminals externally.

(6) Transistor output (ESCP type) (Y120-Y123 of EH-D64EDTPS)

Item	Specification	Circuit diagram	
Output specification	Transistor output (with short-circuit protection)	<p>Source type [EH-D64EDTPS] (Y120-Y123)</p>	
Rated load voltage	24/12 V DC (+10 %, -15 %)		
Minimum switching current	10 mA		
Leak current	0.1 mA (max)		
Maximum load current	1 circuit		1 A
	1 common		3 A
Output response time	OFF → ON		0.5 ms (max) 24 V DC
	ON → OFF		0.5 ms (max) 24 V DC
Number of output points	4 pts. (Refer to Terminal layout and wiring)		
Number of common	1 pts. (Refer to Terminal layout and wiring)		
Surge removing circuit	None		
Fuse	None		
Insulation system	Photocoupler insulation		
External connection	Removable type screw terminal block (M3)		
Externally supplied power *1	12 to 30 V DC		
Insulation	1500 V or more (external-internal)		
	500 V or more (external-external)		
Output voltage drop	0.3 V DC (max)		

*1: It is necessary to supply 12 to 30 V DC between the V and C terminals externally.

■ Terminal layout and wiring (64 Points type)

EH-A64EDR (AC power type)

* For the DC input, both sink and source type are available. It is possible to reverse the polarity of 24VDC.

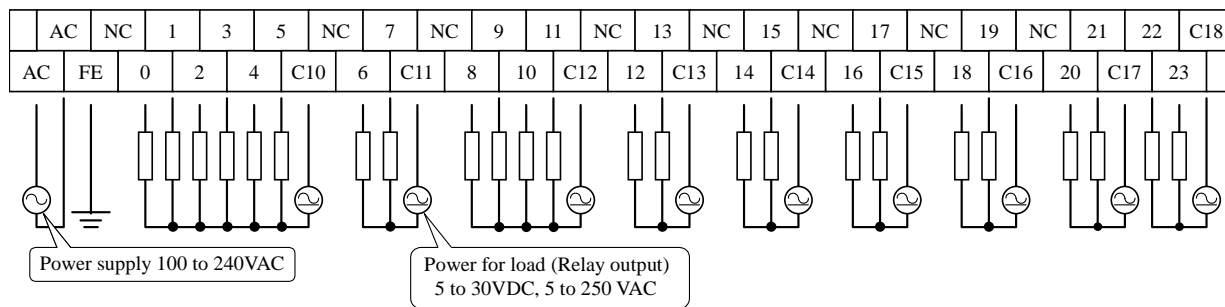
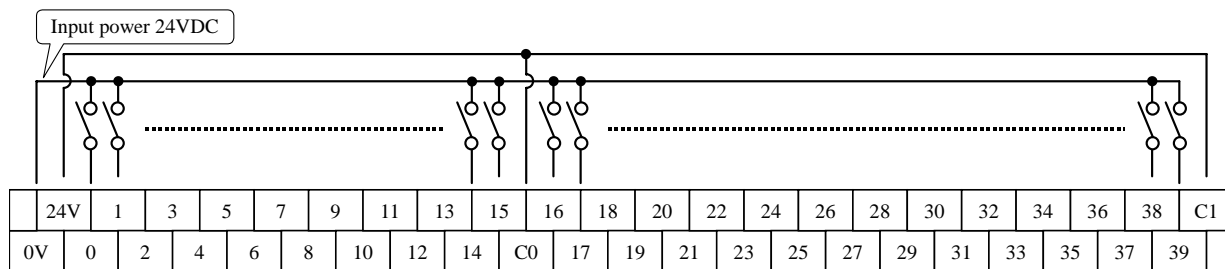

EH-D64EDR (DC power type) (Input wiring is same as EH-A64EDR)

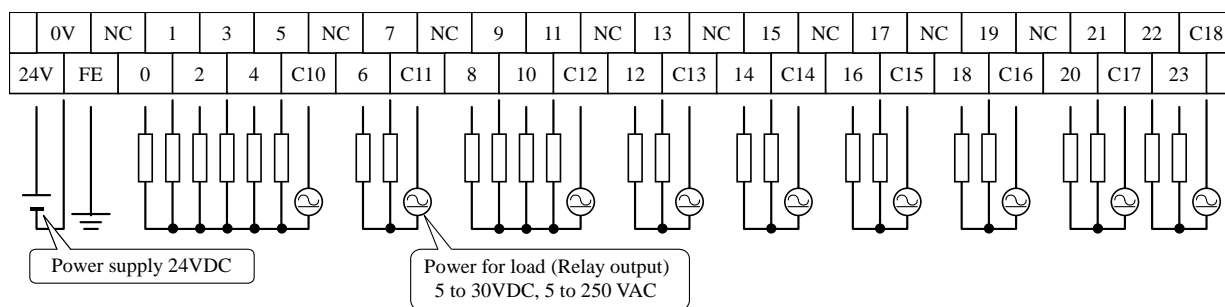

EH-D64EDTPS (DC power type) (Input wiring is same as EH-A64EDR)

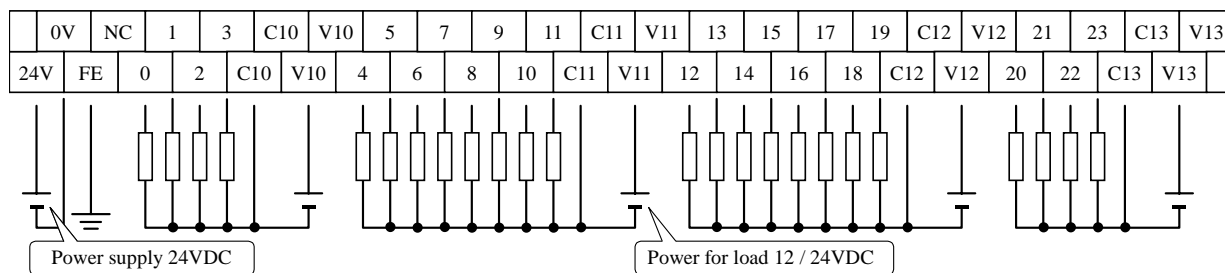

EH-D64EDT (DC power type) (Input wiring is same as EH-A64EDR)

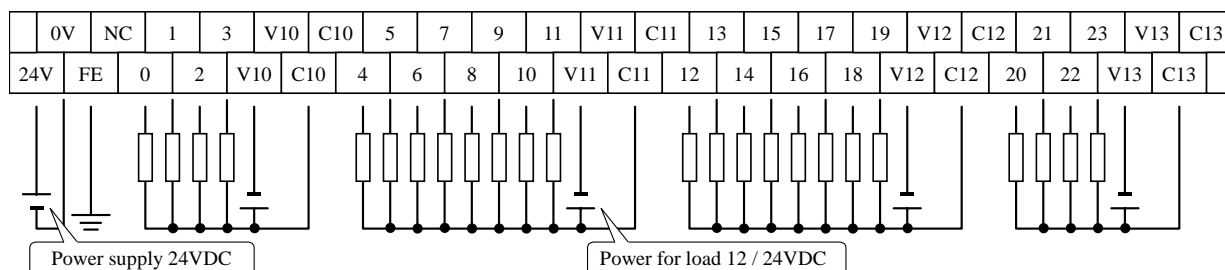

■ Note

- Supported basic unit

The basic unit produced in March 2008 or later is supported.

Basic Unit	Version	Remarks
10-point type	—	Cannot expand
14-point type	Ver. 3.00 (WRF051 = H0300) or newer	MFG No. 08C13 or later
23 / 28-point type	Ver. 3.10 (WRF051 = H0310) or newer	MFG No. 08C01 or later
20 / 40 / 64-point type	Ver. 1.40 (WRF051 = H0140) or newer	MFG No. 08D01 or later
Web controller	—	64 points expansion unit is not supported

Notice

If the basic-unit firmware is not corresponding for 64 points expansion unit,

(1) 14,23 and 28 points basic unit can't write the program because it becomes undefined IO error if read the mounting IO assignment.

Also if you defined the IO assignment as 【X48】 - 【Y32】 - 【empty16】 , IO assign error(Error code 41) will happen.

(2) 20,40,64 points basic unit and Web controller (23point) read IO assignment of 64 points expansion unit as 【B1/1】 . Therefore a part of IO will not works correctly.

Also if you defined the IO assignment as 【X48】 - 【Y32】 - 【empty16】 , IO assign error(Error code 41) will happen.

- Field wiring

Use copper conductors for all wiring. You can use one copper conductor - AWG#14 (2.1 mm²) through AWG#22 (0.36 mm²) or two copper conductors – AWG#16 (1.3 mm²) through AWG#22 (0.36 mm²) – per terminal.

- Suggested torque

The suggested torque for terminal connections is 0.5 to 0.6 Nm.

- UL

This unit is industrial control equipment for use in hazardous locations "class I, Division2, Groups A,B,C,D"

WARNING: EXPLOSION HAZARD

- SUBSTITUTION OF COMPONENTS MAY IMPAIR SUITABILITY FOR CLASS I, DIVISION 2.
- DO NOT REPLACE MODULES UNLESS POWER HAS BEEN SWITCHED OFF OR THE AREA IS KNOWN TO BE NON-HAZARDOUS.
- DO NOT DISCONNECT EQUIPMENT UNLESS POWER HAS BEEN SWITCHED OFF OR THE AREA IS KNOWN TO BE NON-HAZARDS.
- DO NOT CONNECT OR DISCONNECT CABLE UNLESS POWER HAS BEEN SWITCHED OFF OR THE AREA IS KNOWN TO BE NON-HAZARDOUS.