

<b>Application Note</b>	<b>AN-ODE-01</b>		
<b>Title</b>	<b>E2 Modbus RTU Register Map</b>		
Revision History			
Version	Comments	Author	Date
1.02	Previous version	PAE	11/06/08
1.03	Revised to new format	PAE	09/03/09

## General

This document details the Modbus RTU memory mapping that is implemented in the Optidrive E2 drives, detailing which addresses are used to read and write data to / from Optidrive E2 in a Modbus RTU network.

Note that for E2 drive, once the Modbus control/monitor is enabled (P-36>0), the Optibus network function will be disabled, therefore disabling the Optiport E2 remote keypad and Optistick.

:

For control & monitoring of the drives the following parameters should be set correctly:

- P-12 : (set to 3 for Modbus without ramp control or 4 for Modbus with ramp control )
- P-36 : (communication address, baud rate and comms loss trip time)
- P-15 (Analog and Digital input configuration)

For monitoring of the drives the following parameters should be set correctly:

- P-36 : (communication address, baud rate and comms loss trip time)
- P-15 (Analog and Digital input configuration)

Please see **User Guide** for more information on these parameter settings

The Fieldbus Gateways (Profibus, DeviceNet & Ethernet) also use the Modbus interface. In this case, the baud rate must be set to 57.6kbps. For more information regarding the fieldbus gateway, please contact your local distributor, or visit our web site: [www.invertek.co.uk](http://www.invertek.co.uk)

Invertek Drives Ltd adopts a policy of continuous improvement and whilst every effort has been made to provide accurate and up to date information, the information contained in this document should be used for guidance purposes only and does not form the part of any contract.

### MODBUS RTU Protocol Specification

The following table highlights the specification for the Modbus RTU implementation in E2

<b>Protocol</b>	Modbus RTU
<b>Error check</b>	CRC
<b>Baud rate (P-36)</b>	9600bps, 19200bps, 38400bps, 57600bps, 115200bps (default)
<b>Data format</b>	1 start bit, 8 data bits, 1 stop bits, no parity.
<b>Physical signal</b>	RS 485 (2-wire)

### RJ45 Data Connection Pin Configuration

#### For drives with software V1.00 & V1.01

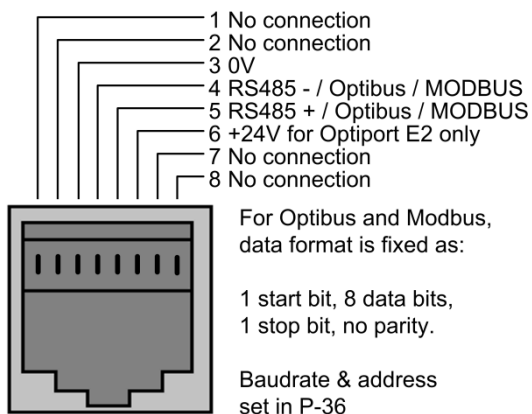

#### For drives with software V1.02 & later

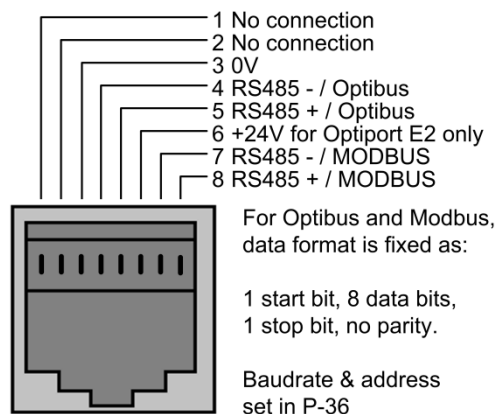

### Typical MODBUS configuration

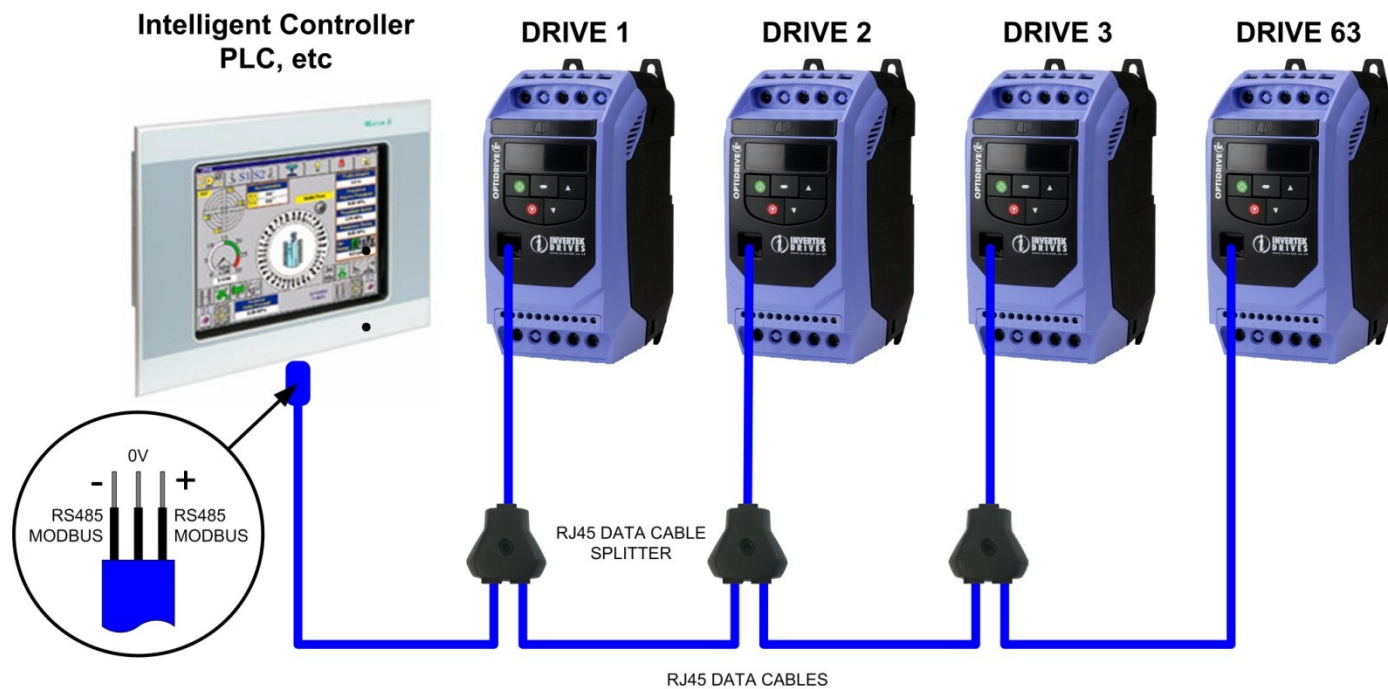

## Memory Map

**Table 1: Control and status registers**

Register	Upper byte	Lower Byte	Command	Type
1*	Command		03,06	Read/Write
2*	Speed reference		03,06	Read/Write
3*	Reserved		03,06	Read/Write
4*	Modbus ramp control time		03,06	Read/Write
5	Reserved		03	Read Only
6*	Error code	Drive status	03	Read Only
7*	Motor speed		03	Read Only
8*	Motor current		03	Read Only
9*	Reserved		03	Read Only
10	Reserved		03	Read Only
11	Digital input status		03	Read Only
12	Rating ID		03	Read Only
13	Power rating		03	Read Only
14	Voltage rating		03	Read Only
15	IO processor software version		03	Read Only
16	Motor control processor software version		03	Read Only
17	Drive type		03	Read Only
18	Reserved		03	Read Only
19	Reserved		03	Read Only
20	Analog 1 input result		03	Read Only
21	Analog 2 input result		03	Read Only
22	Speed reference value		03	Read Only
23	DC bus voltages		03	Read Only
24	Drive temperature		03	Read Only
25 to 30	Reserved		03	Read Only

\* When using the external fieldbus gateways (PROFIBUS, DEVICENET, ETHERNET) these registers are available.

## Control and Status Register Descriptions

### Read and write registers

Register 1: Drive command

15	14	13	12	11	10	9	8	7	6	5	4	3	2	1	0
High byte								Low byte							

Bit 0: Run/Stop command: Set to 1 to enable the drive. Set to 0 to stop the drive.

Bit 1: Fast stop request. Set to 1 to enable drive to stop with 2<sup>nd</sup> deceleration ramp.

Bit 2: Reset request. Set to 1 in order to reset the drive if drive is under trip condition.

User **must** clear this bit when drive is under normal condition to prevent un-expected reset.

Bit 3: Coast stop request. Set to 1 to issue a coast stop command.

For normal operation, Bit 3 has the highest priority, bit 0 has the lowest priority (bit 3>bit 1>bit 0). For example if user set command as 0x0009, drive will do a coast stop rather than run. For normal run/start, just set this register to 1.

Note that stat/stop(bit 0), fast stop(bit 1) and coast stop(bit 3) only works if P-31= 0 or 1. Otherwise, start/stop function is controlled by drive control terminals. Reset function(bit 2) works all the time as long as drive is operated under Modbus control mode (P-12=3 or 4).

Register 2: speed reference setup

This register holds the speed reference value. The input data is 16bits integer and it also includes one decimal place. For example, value 500 represents the 50.0Hz, value 123 gives 12.3Hz. To get negative speed reference, user needs put negative value into this register. For example, -1(0xFFFF) gives -0.1Hz. -234(0xFF16) gives -23.4Hz.

The input value range from -5000 (0 for single phase output drive) to +5000, however the drive output speed will be limited by the maximum speed set by P-01.

Register 4: Modbus ramp control time

This register specifies the drive acceleration and deceleration ramp time. User can only write to this register when P-12 is set to 4. The input data range is from 0 to 60000 (0.00s to 600.00s)

### Read only registers

Register 6: Drive status and error code

High byte gives drive error code. (Valid when drive tripped, see appendix for details)

Low byte gives drive status (0: drive stopped, 1: drive running, 2: drive tripped)

Register 7: Motor speed information

This register gives motor speed information.

The data is 16bits integer with one decimal place. E.g. value 123 gives 12.3Hz. Value -234 (0xFF16) gives -23.4Hz.

Register 8: Motor current

This register gives motor current information.

The data is 16bits integer with one decimal place. E.g. 156 = 15.6A, 12 = 1.2A.

Register 11: Digital input status

The value in this register represents the drive terminal digital input status (Digital input 1 to 4). Lowest bit indicates digital input 1 status.

#### Register 12: Rating ID

The value in this parameter includes specific drive ID information, and is not recommended to be used by customer. For more information regarding this parameter, please contact Invertek Drives Ltd directly.

#### Register 13: Power rating

This gives the drive power rating information, value includes two decimal places. The unit of this register depends on the drive type (KW/HP)

#### Register 14: Voltage level

This register gives the rated input voltage for the drive.

i.e. 230 : 230V    400: 400V    460: 460V

#### Register 15: IO software version

This register contains the drive IO software version info. Value includes two decimal places.

i.e. 100 means version 1.00

#### Register 16: Motor control processor software version

This register contains the software version info of the motor control processor. Value includes two decimal places. E.g. 100 means version 1.00

#### Register 17: Drive type

This register gives drive internal type code.

#### Register 20: Analog input 1 value

This register gives drive analog input 1 value after scaling and offset control. Value 4096 = 100%.

#### Register 21: Analog input 2 value

This register gives drive analog input 2 value after scaling and offset control. Value 4096 = 100%.

#### Register 22: Speed reference value

This register contains the reference speed information that being used by the drive for motor speed control. The data is in Hz and with one decimal place ( i.e. 234 = 23.4Hz)

#### Register 23: DC bus voltage

This register contains drive internal DC bus voltage information. Data unit is Volt.

#### Register 23: Drive temperature

This register contains drive temperature information. Data is in Celsius with no decimal place.

**Table 2: Parameter registers****(Support command 03 and 06)**

Adr	Par	Description	Data range	Data format
129	01	Max speed limit	0 to 50 * P-09	Internal value (3000 = 50.0Hz)
130	02	Min speed limit	0 to P-01	Internal value (3000 = 50.0Hz)
131	03	Accel ramp time	0 to 60000	One decimal place 300=3.00s
132	04	Decel ramp time	0 to 60000	One decimal place 300=3.00s
133	05	Stop mode select	0 to 2	0: Ramp to stop 1: Coast to stop 2: Ramp to stop
134	06	Energy save	0 ,1	0: Disable 1: Enable
135	07	Motor rated voltage	0, 20 to 250 V 0, 20 to 500 V	
136	08	Motor rated current	Drive dependent	One decimal place 300=30.0A
137	09	Motor rated frequency	25 to 500	Data unit is in Hz
138	10	Motor rated speed	0 to Sync speed	Maximum value equals to the sync speed of a typical 2-pole motor
139	11	Boost voltage value	Size 1 - 0 to 200 Size 2 - 0 to 150 Size 3 - 0 to 100	100 = 10.0%
140	12	Control mode	0 to 6	0: Terminal 1: Keypad forward only 2: Keypad forward and reverse 3: Modbus control mode 4: Modbus control with ramp control 5 : PID control 6 : PID control with analog speed sum
141	13	Trip log		Last four trips (See Appendix for details )
142	14	Access code	0 to 9999	
143	15	Digital input function	0 to 12	See user guide for function details
144	16	Analog input format	0 to 6	0: 0...10V 1: b 0...10V 2: 0...20mA 3: t 4...20mA 4: r 4...20mA 5: t 20...4mA 6: r 20...4mA
145	17	Effective switching frequency	0 to 5 and it is drive dependent	0 = 4KHz, 1 = 8KHz, 2 = 12KHz 3 =16KHz, 4 = 24KHz, 5 = 32KHz
146	18	Relay output function	0 to 7	See user guide for function details
147	19	Digital output limit	0...1000	100 = 10.0%
148	20	Preset speed 1	-P-01 to P-01	Internal value (3000 = 50.0Hz)
149	21	Preset speed 2	-P-01 to P-01	Internal value (3000 = 50.0Hz)
150	22	Preset speed 3	-P-01 to P-01	Internal value (3000 = 50.0Hz)
151	23	Preset speed 4	-P-01 to P-01	Internal value (3000 = 50.0Hz)
152	24	2 <sup>nd</sup> deceleration ramp	0 to 2500	250 = 25.0s
153	25	Analog output function	0 to 9	See user guide for function details
154	26	Skip frequency	0 to P-01	Internal value (3000 = 50.0Hz)
155	27	Skip freq band	0 to P-01	Internal value (3000 = 50.0Hz)
156	28	V/F adjust voltage	0 to P-07	100 = 100V
157	29	V/F adjust frequency	0 to P-09	50 = 50Hz
158	30	Start mode select	0 to 6	0: Edgr-r 1: Auto_0 2...6: Auto_1 to Auto_5

Adr	Par	Description	Data range	Data format
159	31	Keypad restart mode	0 to 3	See user guide for details
160	32	DC injection enable	0 to 250	250= 25.0s
161	33	Spin start enable	0 or 1	
162	34	Brake circuit enable	0 to 2	See user guide for function details
163	35	Analog input scaling	0 to 5000	100 = 10%
164	36	Drive address (Low byte)	0 to 63	Drive comms address
		Baudrate select	1 to 6	1 = Optibus fixed baudrate 2 = 9K6            3 = 19K2 4 = 38K4         5 = 57K6 6 = 115K2
		Trip time setup	0 to 8	See user guide for more information
165	37	Access code definition	0 to 9999	
166	38	Parameter lock	0 or 1	0: Unlock    1: Locked
167	39	Analog input offset	-5000 to 5000	One decimal place 300=30.0%
168	40	Display scaling factor	0 to 6000	100 = 0.100
169	41	User PI P gain	1 to 300	10 = 1.0
170	42	User PI I time constant	0 to 300	10 = 1.0s
171	43	User PI mode select	0 or 1	See user guide for more information
172	44	User PI reference select	0 or 1	See user guide for more information
173	45	User PI digital reference	0 to 1000	100 =10.0%
174	46	User PI feedback select	0 to 3	See user guide for more information
175	47	2 <sup>nd</sup> an input format	0 to 5	0: 0...10V    1: 0...20mA 2: t 4...20mA    3: r 4...20mA 4: t 20...4mA    5: r 20...4mA

## Appendix

### Drive error code information in Register 6:

Drive Error Code	Drive Display Fault Code	Description
0x00	StoP	Drive healthy no fault present When the drive is disabled the display will STOP. The display will change if drive is running.
0x01	OI -b	Brake channel over current
0x02	OL-br	Brake resistor overload
0x03	O-I	Over current on drive output. Excess load on the motor. Over temperature on the drive heatsink
0x04	I.t-erP	Drive has tripped on overload after delivering >100% of value in P-08 for a period of time.
0x05	PS-erP	Internal power stage fault
0x06	O.Uo It	Over voltage on DC bus
0x07	U.Uo It	Under voltage on DC bus
0x08	O-t	Heatsink over temperature
0x09	U-t	Under temperature
0x0A	P-dEF	Factory Default parameters have been loaded
0x0B	E-er iP	External trip (on digital Input 3)
0x0C	SC-erP	Serial communications loss trip
0x0D		RESERVED
0x0E	P-LOSS	Input phase loss trip
0x0F	SPI n-F	Spin start failed
0x10	th-FLt	Faulty thermistor on heatsink.
0x11	dAtA-F	Internal memory fault.
0x12	4-20 F	Analog input current out of range (4-20mA)



**Dataflow example:**

Read data from register 6:

Request:	[01] (Drive Addr)	[03] (Command)	[00] [05] (Reg start addr)	[00] [01] (No. of Registers)	[94] [0B] (Checksum)
Reply:	[01] (Drive Addr)	[03] (Command)	[02] (No of data bytes)	[00] [00] (Data)	[B8] [44] (Checksum)

Note: The actual start address of register 6 is 5. All data in [ ] is in 8bits Hex format.

Write start command to the register 1 (suppose P-12 = 3, P-15 =0 and digital input 1 is closed):

Request:	[01] (Drive Addr)	[06] (Command)	[00] [00] (Reg addr)	[00] [01] (Data value)	[48] [0A] (Checksum)
Reply:	[01] (Drive Addr)	[06] (Command)	[00] [00] (Reg addr)	[00] [01] (Data value)	[48] [0A] (Checksum)

Note: The actual address of register 1 on the data link is 0. All data in [ ] is in 8bits Hex format.

Reply can be error message depending on drive parameter settings and digital input status.

### Analog and Digital Input Configurations when in MODBUS control mode (P12 = 3 or 4)

By changing the value in P-15 adjusts the functionality of the control terminals as below:

P-15	Digital input 1 (T2)	Digital input 2 (T3)	Digital input 3 (T4)	Analog input (T6)	Comments
0..2, 4..5, 8..12	Open: Stop (disable) Closed: Run (enable)	No effect	No effect	No effect	Run and stop commands given via the RS485 link and Digital input 1 must be closed for the drive to run.
3 <sup>1)</sup>	Open: Stop (disable) Closed: Run (enable)	Open : Master speed ref Closed : Preset speed 1	External trip input : Open: Trip, Closed: Run	No effect	Connect external thermistor type PT100 or similar to digital input 3
6 <sup>1)</sup>	Open: Stop (disable) Closed: Run (enable)	Open : Master speed ref Closed : Analog input	External trip input : Open: Trip, Closed: Run	Analog input reference	Master Speed Ref - start and stop controlled via RS485. Keypad Speed Ref - drive auto runs if digital input 1 closed, depending on P-31 setting
7 <sup>1)</sup>	Open: Stop (disable) Closed: Run (enable)	Open : Master speed ref Closed : keypad speed ref	External trip input : Open: Trip, Closed: Run	No effect	

#### Example Wiring

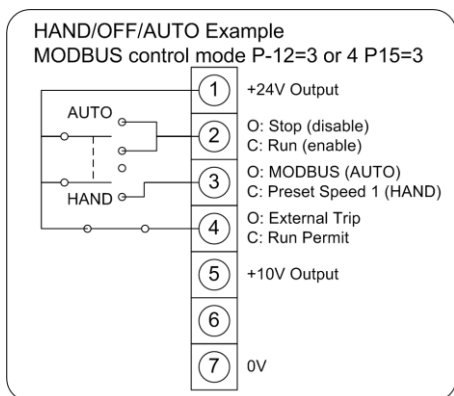

AUTO – MODBUS Speed  
HAND – Preset Speed 1

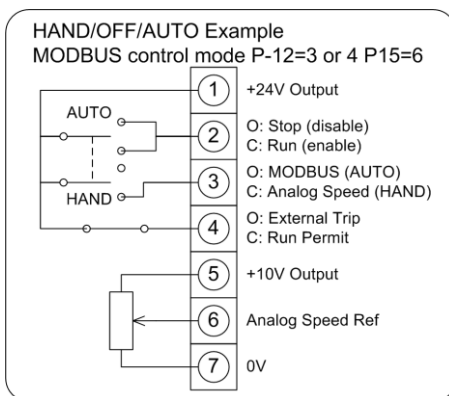

AUTO – MODBUS Speed  
HAND - Analog Speed ref  
(potentiometer)

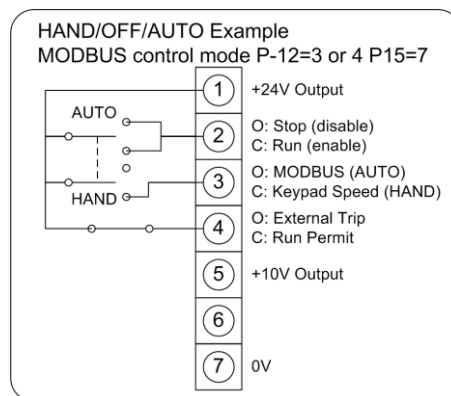

AUTO – MODBUS Speed  
HAND – Keypad Speed ref (UP & DOWN keys on drive)

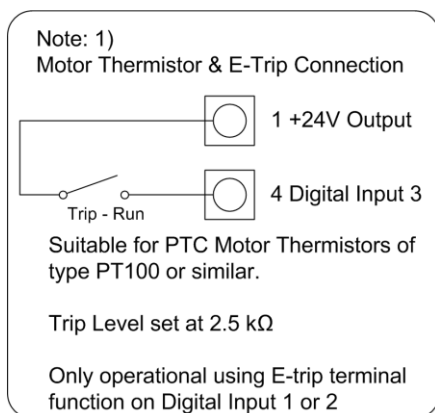

**Register Changes for E2 Single Phase Output Drives**

The Optidrive E2 Single Phase Output drive has some registers that are different to the stand Optidrive E2, for this reason the Registers/Parameters are listed below:

<b>Adr</b>	<b>Par</b>	<b>Description</b>	<b>Data range</b>	<b>Data format</b>
134	06	Reserved		
148	20	Preset speed 1	0 to P-01	Internal value (3000 = 50.0Hz)
149	21	Preset speed 2	0 to P-01	Internal value (3000 = 50.0Hz)
150	22	Preset speed 3	0 to P-01	Internal value (3000 = 50.0Hz)
151	23	Preset speed 4	0 to P-01	Internal value (3000 = 50.0Hz)
160	32	Boost Frequency	0 to P09	50 = 50Hz
161	33	Boost Period Duration	0 to 150s	100 = 10.0 seconds

--- End ---